

- **Ideal for 318.00 MHz Transmitters**
- **Very Low Insertion Loss**
- **Quartz Stability**
- **Miniature Ceramic QCC4A SMD Package**
- **Complies with Directive 2002/95/EC (RoHS Compliant)**

SR5418

ABSOLUTE MAXIMUM RATINGg ($T_A=25^{\circ}\text{C}$)		
Parameter	Rating	Unit
CW RF Power Dissipation	P	0
DC Voltage	V_{bc}	± 30
Operating Temperature Range	T_A	-10 ~ +60
Storage Temperature Range	T_{stg}	-40 ~ +85

ELECTRONIC CHARACTERISTICS						
Parameter	Sym	Minimum	Typical	Maximum	Unit	
Frequency (25°C)	Nominal Frequency	f_c	NS	318.00	NS	MHz
	Tolerance from 318.00 MHz	Δf_c	-	-	± 75	KHz
Insertion Loss		IL	-	1.2	1.8	dB
Quality Factor	Unloaded Q-Value	Q_u	-	14,550	-	-
	50Ω Loaded Q-Value	Q_L	-	1,900	-	-
Temperature Stability	Turnover Temperature	T_o	25	-	55	°C
	Turnover Frequency	f_o	-	f_c	-	KHz
	Frequency Temperature Coefficient	FTC	-	0.032	-	ppm/°C ²
Frequency Aging	Absolute Value during the First Year	$ f_A $	-	-	10	ppm/yr
DC Insulation Resistance Between any Two Pins		-	1.0	-	-	MΩ
RF Equivalent RLC Model	Motional Resistance	R_M	-	15.0	23.0	Ω
	Motional Inductance	L_M	-	109.4119	-	μH
	Motional Capacitance	C_M	-	2.2917	-	fF
	Shunt Static Capacitance	C_o	2.4	2.7	3.0	pF

NS = Not Specified

Note:

- The frequency f_c is the frequency of minimum IL with the resonator in the specified test fixture in a 50Ω test system with VSWR $\leq 1.2:1$.
- Unless noted otherwise, case temperature TC = +25°C±2°C.
- Frequency aging is the change in fC with time and is specified at +65°C or less. Aging may exceed the specification for prolonged temperatures above +65°C. Typically, aging is greatest the first year after manufacture, decreasing in subsequent years.
- Turnover temperature, T₀, is the temperature of maximum (or turnover) frequency, f₀. The nominal frequency at any case temperature, TC, may be calculated from: $f = f_o [1 - FTC (T_o - T_C)^2]$.
- This equivalent RLC model approximates resonator performance near the resonant frequency and is provided for reference only. The capacitance C₀ is the measured static (nonmotional) capacitance between input terminal and ground or output terminal and ground.
- The measurement includes case parasitic capacitance.
- Derived mathematically from one or more of the following directly measured parameters: f_c , IL, 3 dB bandwidth, f_c versus T_C, and Co.
- The specifications of this device are based on the test circuit shown above and subject to change or obsolescence without notice.
- Typically, equipment utilizing this device requires emissions testing and government approval, which is the responsibility of the equipment manufacturer.
- Our liability is only assumed for the Surface Acoustic Wave (SAW) component(s) per se, not for applications, processes and circuits implemented within components or assemblies.
- For questions on technology, prices and delivery, please contact our sales offices or e-mail to sales@vanlong.com.

PACKAGE DIMENSIONS (QCC4A)

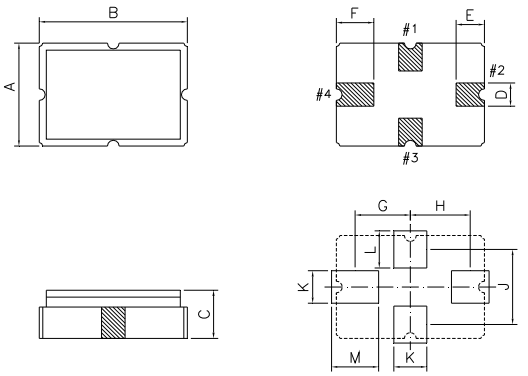

Recommended PC Board Layout

Electrical Connections

Terminals	Connection
1	Input / Output
3	Output / Input
2,4	Case-Ground

Package Dimensions

Dimensions	Nom (mm)	Dimensions	Nom (mm)
A	3.5	G	1.9
B	5.0	H	2.15
C	1.4	J	2.8
D	0.5	K	0.7
E	0.8	L	1.3
F	1.2	M	1.8

MARKING



- Laser or Ink Marking
- SR5418 - Part Code
 - Date Code:
 Y : Last digit of year
 WW : Week No.

EQUIVALENT LC MODEL AND TEST CIRCUIT

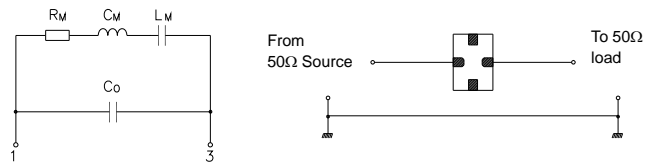

Equivalent LC Model

Typical Test Circuit

TYPICAL APPLICATION CIRCUIT

Low Power Transmitter Application

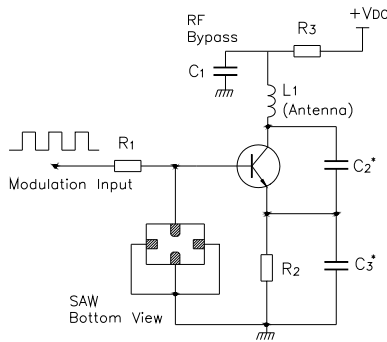

Local Oscillator Application

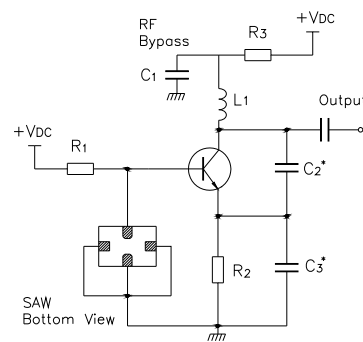

TYPICAL FREQUENCY RESPONSE

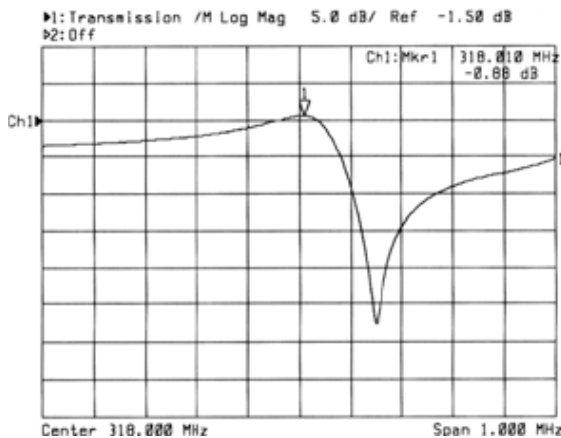

TEMPERATURE CHARACTERISTICS

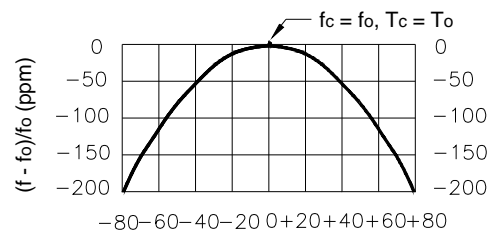

$$\Delta T = T_c - T_o \text{ (}^\circ\text{C)}$$

The curve shown above accounts for resonator contribution only and does not include oscillator temperature characteristics.

ENVIRONMENTAL CHARACTERISTICS		
Item	Condition of Test	Requirements
Random Drop	The Filter shall be measured after 3 times random drops from the height of 30cm on concrete floor.	No visible damage and the measured values shall remain the Electronic Characteristics after tests.
Vibration	The Filter shall be measured after being applied vibration of amplitude of 1.5mm with 10Hz to 55Hz bands of vibration frequency to each of 3 perpendicular directions for 1 hour.	
Lead Pulling Test	A weight of 3kg is pulled towards an axis of each terminal for 10 seconds.	
Lead bending Test	Lead shall be subject to withstand against 90 bending at its stem. This operation shall be done toward both directions.	
Resistance to Soldering Heat	Lead terminals are immersed up to 1.5mm from the Filter's body in solder bath of 270°C ± 10°C for 10 ± 1 seconds, and then the Filter shall be measured after being placed in natural condition for 2 hour.	
Solderability	Lead terminals are immersed in resin for 5 seconds and then immersed in soldering bath of 270°C ± 10°C for 2 ± 0.5 seconds.	
High Temperature Storage	After being placed in a chamber with +85°C ± 2°C for 96 ± 4 hours and then being placed in natural condition for 2 hour. The Filter shall be measured.	
Low Temperature Storage	After being placed in a chamber with -40°C ± 2°C for 96 ± 4 hours and then being placed in natural condition for 2 hour. The Filter shall be measured.	
Humidity	After being placed in a chamber with 90 to 95% R.H. at +40°C ± 2°C for 96 ± 4 hours and then being placed in natural condition for 2 hour. The Filter shall be measured.	
Heat Shock	After being kept at room temperature, the Filter shall be placed at temperature of -40°C for 30 minutes, and then the Filter shall be immediately placed at temperature of 85°C, after 30 minutes at temperature of 85°C, the Filter shall be returned to -40°C again. After 5 times above cycles, the Filter shall be returned to room temperature, after 2 hour in natural condition, the Filter shall be measured.	

